

SUPPLEMENT TO FIRE RESISTANCE CLASSIFICATION REPORT No. 14040A

Fire resistance on a reactive air transfer grille Gz60

Owner of the classification report:

RF-TECHNOLOGIES
Lange Ambachtstraat 40
9860 OOSTERZELE
BELGIUM

This report is a supplement to that issued as no. 14040A, dated 2009/07/16 and consists of 2 pages. This report is drafted in accordance with the regulations of EGOLF Agreement EGA 08rev:2012 "Application note: clause 5.10 / 3 – Rectification of errors in reports". There were some errors in the original report, the test specimen involved has not been retested. The present report contains technical modifications to the original report. All the changes to the original report are documented by the laboratory and maintained in the laboratory records and are double underlined in this document. The report should be added to the original report and may only be used in conjunction with the original report.

Rectification of error on page 4:**2.3.3 Mounting in a flexible wall (Test reports N°s 13439A and 13440A)**

The reactive air transfer grilles are mounted in a flexible plasterboard wall with a thickness of 100 mm in a rectangular opening of 800 mm (Bn) x 400 mm (Hn).

The wall is mounted with profiles of 50 mm thick and a double layer of paper faced gypsum boards (type GKA according to the European standard EN 520) with a thickness of 12,5 mm each on both sides. Between the boards and the profiles rock wool of 40 kg/m³ (NV) and a thickness of 40 mm is placed. To create the opening of 800 mm (Bn) x 400 mm (Hn) a calcium silicate strip of 15 mm thick is screwed to the wall.

The opening between the air transfer grilles and the wall is filled with silicone mastic as well as the gap between the finishing frame and the wall. The gap between the grilles and the wall is between 2 and 3 mm. The gap between the finishing frames and the wall is 3 mm.

SIGNED

APPROVED

This document is the original version of this classification report and is written in English.

This report may be used only literally and completely for publications. - For publications of certain texts, in which this report is mentioned, our permission must be obtained in advance.

The authenticity of the electronic signatures is assured by Belgium Root CA.

Classification report No. 14040A

Fire resistance on a reactive air transfer grille Gz60

Owner of the classification report:

RF-TECHNOLOGIES
Lange Ambachtstraat 40
9860 OOSTERZELE
BELGIUM

This classification report consists of eleven pages and six annexes and may only be used or reproduced in its entirety.



WFRGENT NV - Ottergemsesteenweg-Zuid 711 - B-9000 Gent - België
t: +32/(0)9 243 77 50 - f: +32/(0)9 243 77 51 - e: info@warringtonfiregent.net
BTW/VAT/TVA BE0870.418.414 - Ondernemingsnummer : RPR 0870.418.414 GENT



1 Introduction

This classification report defines the classification assigned to a fire resistant reactive air transfer grille named Gz60 in accordance with the procedures given in EN 13501-2: 2007: Fire classification of construction products and building elements - Part 2: Classification using data from fire resistance tests, excluding ventilation services.

2 Details of classified product

2.1 General

The element Gz60, is defined as a reactive air transfer grille. Its function is to resist the spread of fire and hot gases by the intumescent action of its active components, in respect of the fire performance characteristics integrity, thermal insulation and radiation in clause 5 of EN 13501-2: 2007.

2.2 Product description

The reactive air transfer grille consists of a frame, horizontal slates and optionally a finishing frame for grills in vertical separating elements.

2.2.1 Air transfer grille frame

The frame is composed of two vertical profiles and two horizontal profiles. The profiles are composed of two strips of intumescent product protected by a plastic case profile. The horizontal and vertical frame profiles are connected with a plastic corner bracket.

2.2.2 Horizontal intermediate slates

The horizontal intermediate slates are composed of two strips of intumescent product protected by a plastic case profile. The horizontal intermediate slates are attached to each other and to the frame by means of eight steel bars. Over those bars a distance holder is placed. The intermediate distance in between the slates is 13.5 mm. The axis-to-axis distance between the slates is 20 mm.

The vertical frame profiles are fixed at four places to the horizontal intermediate slates by means of screws.

2.2.3 Finishing frame

The finishing frame is composed of four parts: two horizontal profiles and two vertical profiles. The profiles are connected with aluminium corner brackets. The entire finishing frame is glued to the air transfer grille.

2.2.4 Actuating mechanism

The intumescent elements swell when exposed to heat and seal off the air path through the grille. There is no mechanical actuating mechanism.

2.3 Mounting

The fire resistant reactive air transfer grilles can be mounted in an aerated concrete wall, in an aerated concrete floor and in a flexible wall.

2.3.1 Mounting in an aerated concrete wall (Test reports N°s 13438A and 13439A)

The reactive air transfer grille is mounted in an aerated concrete wall (density: 550 kg/m³) with a minimum thickness of 100 mm in a rectangular opening of 800 mm (Wn) x 400 mm (Hn). The gap between the air transfer grilles and the wall is filled with a silicone mastic glue as well as the gap between the finishing frame and the wall. The gap between the grilles and the wall is around 2 to 3 mm.

Test report 13438A

	Height of the centre	Finishing frame
Air transfer grille 1	2500 mm	Unexposed side
Air transfer grille 2	500 mm	Unexposed side
Air transfer grille 3	2500 mm	Not applicable
Air transfer grille 4	500 mm	Not applicable

Test report 13439A

	Height of the centre	Finishing frame
Air transfer grille 3	2500 mm	Exposed side
Air transfer grille 4	500 mm	Exposed side

2.3.2 Mounting in an aerated concrete floor (Test report N° 13437A)

The reactive air transfer grilles are mounted in an aerated concrete (density: 650 kg/m³) floor construction with a minimum thickness of 100 mm in a rectangular opening of 860 mm x 460 mm ((W_n + 60)x(H_n + 60)).

The gap between the air transfer grilles and the floor is filled with a frame consisting of calcium silicate strips fixed to the aerated concrete slabs. The gap between the frame and the floor is between 6 to 18 mm and is filled with mortar for the entire thickness of the floor. The air transfer grilles are mounted at 25 mm from the exposed side of the floor. The grilles are either glued to the frame or simply resting on the calcium silicate frame.

2.3.3 Mounting in a flexible wall (Test reports N°s 13439A and 13440A)

The reactive air transfer grilles are mounted in a flexible plasterboard wall with a thickness of 100 mm in a rectangular opening of 800 mm (B_n) x 400 mm (H_n).

The wall is mounted with profiles of 50 mm thick and a double layer of paper faced gypsum boards (type F according to the European standard EN 520) with a thickness of 12,5 mm each on both sides. Between the boards and the profiles rock wool of 40 kg/m³ (NV) and a thickness of 40 mm is placed. To create the opening of 800 mm (B_n) x 400 mm (H_n) a calcium silicate strip of 15 mm thick is screwed to the wall.

The opening between the air transfer grilles and the wall is filled with silicone mastic as well as the gap between the finishing frame and the wall. The gap between the grilles and the wall is between 2 and 3 mm. The gap between the finishing frames and the wall is 3 mm.

Test report 13440A

	Height of the centre	Finishing frame
Air transfer grille 1	2500 mm	Unexposed side
Air transfer grille 2	500 mm	Unexposed side
Air transfer grille 3	2500 mm	Exposed side
Air transfer grille 4	500 mm	Exposed side

Test report 13439A

	Height of the centre	Finishing frame
Air transfer grille 1	2500 mm	Not applicable
Air transfer grille 2	500 mm	Not applicable

The detailed description of the element, Gz60, is fully given in the test reports

N° 13437A, 13438A, 13439A and 13440A that have been issued in support of this classification and mentioned in clause 3.1.

3 Test reports and test results in support of this classification

There is currently no European testing standard specifically for testing the resistance to fire of reactive air transfer grilles. Therefore, the procedure shall be based on the principle of testing the product as part of an element. In the case of a non-loadbearing element (wall, ceiling, partition etc) the test shall be in accordance with EN 1364-1 or 2.

3.1 Test reports

Name of the laboratory that performed the tests	Identification number of test report	Tested dimension(s) $B_{n \text{ opening}} \times H_{n \text{ opening}}$ (mm) (*)	Supporting construction	Direction of exposure (i – o)	Orientation (h_o , v_e)	Working pressure
WFRGENT NV	13437A	860 x 460	Aerated concrete floor thickness: 100 mm	i↔o	h_o	20 Pa
WFRGENT NV	13438A	800 x 400	Aerated concrete wall thickness: 100 mm	i↔o	v_e	10 Pa -7 Pa
WFRGENT NV	13439A	800 x 400	Gypsum wall thickness: 100 mm Aerated concrete wall thickness: 100 mm	i↔o	v_e	10 Pa -7 Pa
WFRGENT NV	13440A	800 x 400	Flexible wall thickness: 100 mm	i↔o	v_e	10 Pa -7 Pa

($B_{n \text{ opening}}$ = Nominal width opening)

($H_{n \text{ opening}}$ = Nominal height opening)

Exposure conditions of the fire resistance test:

Temperature/time curve: standard as in EN 1363-1: 1999.

Orientation: mounted in a floor construction (h_o = horizontal orientation) and wall construction (v_e = vertical orientation)

ETAG 026-4: 2008 §2.4.2.1. 'Fire resistant reactive air transfer grilles intended for use in either the vertical or the horizontal plane (air flow moving horizontally or vertically) shall be tested in both planes and mounted in appropriately representative substrates.'

Direction of exposure:

Test report 13437A

This concerns a symmetrical construction.

Test report 13438A and 13439A

This concerns a symmetrical and an asymmetrical construction. The asymmetrical air transfer grilles have been tested with the finishing frame at the unexposed side. (Test report 13438A) The asymmetrical air transfer grilles have been tested with the finishing frame at the exposed side. (Test report 13439A)

Test report 13440A

This concerns an asymmetrical construction. The air transfer grilles have been tested once with the finishing frame at the unexposed side and once with the finishing frame at the exposed side.

ETAG 026-4: 2008 §2.4.2.1. 'The grilles shall be tested with exposure to fire to each face, unless the grille is symmetrical in construction.'

One side exposed to the fire.

Level of pressure:

Test report 13437A

The grilles are tested at 20 Pa overpressure at 100 mm below.

Test report 13438A and 13439A

Two air transfer grilles are tested at 10 Pa overpressure.
Two air transfer grilles are tested at 7 Pa underpressure.

Test report 13440A

Two air transfer grilles are tested at 10 Pa overpressure.
Two air transfer grilles are tested at 7 Pa underpressure.
ETAG 026-4: 2008 §2.4.2.1. 'If the product is to be used in both high and low pressure applications, tests must be carried at high and low level in the furnace.'

3.2 Test results

Parameter	Results in minutes			
	WFRG 13437A Aerated concrete floor 100 mm	WFRG 13438A Aerated concrete wall 100 mm	WFRG 13439A Aerated concrete wall 100 mm/ Flexible wall 100 mm	WFRG 13440A Flexible wall
	i↔o	i↔o	i↔o	i↔o
Test duration	88 min	95 min	66 min	61 min
Dimensions grille (mm)	794 x 394	795 x 394	795 x 394	795 x 394
Integrity (E criterion):				
Ignition of the cotton pad during the test after five minutes	85 minutes	95 minutes	≥66 minutes (3)	≥61 minutes (4)
Spontaneous, continuous flames	≥88 minutes (1)	≥95 minutes (2)	≥66 minutes (3)	≥61 minutes (4)
Gap gauge (Ø 6 mm or Ø 25 mm) around the perimeter of the grille	≥88 minutes (1)	≥95 minutes (2)	≥66 minutes (3)	≥61 minutes (4)
Thermal insulation (I criterion):				
A maximum temperature rise of 180°C at the unexposed side	79 minutes	71 minutes	≥66 minutes (3)	≥61 minutes (4)
An average temperature rise of 140°C at the unexposed side	86 minutes	75 minutes	≥66 minutes (3)	≥61 minutes (4)
Radiation (R criterion):				
Reaches 15 kW/m ²	Not applicable	≥95 minutes (2)	≥66 minutes (3)	≥61 minutes (4)

- (1) No failures at test termination (88 minutes).
- (2) No failures at test termination (95 minutes).
- (3) No failures at test termination (66 minutes).
- (4) No failures at test termination (61 minutes).

4 Classification and field of application

4.1 Reference of classification

This classification has been carried out in accordance with clause 7.5.2.3 of EN 13501-2: 2006 and with clause 2.4.2.2 of ETAG 026-4: 2008.

4.2 Classification

The element, including the air transfer grille, Gz60 is classified according to the clause 7.2.3 of EN 13501-2: 2006 and clause 2.4.2.2. of ETAG 026-4:2008.

Since the performance of the grille can be affected by its position in the vertical plane (due to the pressure gradient within the furnace) any classification is restricted to the position tested.

The test reports mentioned in table 3.1 allow a large series of combinations of performance parameters and time categories. At the request of the sponsor, only the classes below are given.

For air transfer grilles without finishing frame placed in a

- **aerated concrete wall with a thickness of 100 mm**
EW 90 ($v_e i \leftrightarrow o$)
E 90 ($v_e i \leftrightarrow o$)
- **aerated concrete wall with a thickness of 100 mm**
- **aerated concrete floor with a thickness of 100 mm**
- **flexible wall with a thickness of 100 mm (*)**
EI 60 ($v_e h_o i \leftrightarrow o$)
EW 60 ($v_e h_o i \leftrightarrow o$)
E 60 ($v_e h_o i \leftrightarrow o$)
EI 30 ($v_e h_o i \leftrightarrow o$)
EW 30 ($v_e h_o i \leftrightarrow o$)
E 30 ($v_e h_o i \leftrightarrow o$)

(*) the above classifications are valid for air transfer grilles tested between 300 mm from the threshold until 2700 mm.

For air transfer grilles with finishing frame placed in a

- aerated concrete wall with a thickness of 100 mm
- flexible wall with a thickness of 100 mm (*)

EI 60 ($v_e i \leftrightarrow o$)

EW 60 ($v_e i \leftrightarrow o$)

E 60 ($v_e i \leftrightarrow o$)

EI 30 ($v_e i \leftrightarrow o$)

EW 30 ($v_e i \leftrightarrow o$)

E 30 ($v_e i \leftrightarrow o$)

(*) the above classifications are valid for air transfer grilles tested between 300 mm and 2700 mm from the threshold.

4.3 Field of direct application

This classification is valid for the following end use applications according to EN 13501-2: 2006, ETAG 026-4: 2008 and EN 1364-1:1999: reactive air transfer grille in walls or floors.

This classification is also valid for the following production varieties:

- Size of the air transfer grille:

The type of grille and the fixings, including type and number of fixings, shall not be changed from those tested.

The dimensions of the grilles may be decreased but shall not be increased from the tested configuration.

- Direction of exposure of the air transfer grille:

Fire resistant reactive air transfer grilles for vertical and horizontal mounting are permitted as mentioned in clause 4.2. of this document.

- **Distance between the reactive air transfer grilles and construction elements:**

For grilles in partitions or ceilings, the grille shall be positioned in the element no closer than 200 mm from the edge of the specimen and between 300 mm and 2700 mm from the threshold.

The filling between the reactive air transfer grille and the wall or floor needs to be done as mentioned in clause 2.3.1, 2.3.2 or 2.3.3 of this document.

- **Supporting constructions:**

A supporting construction of the same type with a fire resistance equal or greater than the tested standard supporting construction (thicker and/or denser, more layers of board).

The results of the fire test are directly applicable to mounting in a similar supporting construction with one or more of the following changes:

Aerated concrete wall

The height of an identical construction may be increased to 4 m.

Aerated concrete wall – Flexible wall



- Decrease in height
- Increase in thickness of the wall
- Flexible wall
 - Increase in thickness of the component materials
 - Decrease in linear dimensions of the boards, but not thickness
 - Decrease in stud spacing
 - Decrease in distance of fixing centres

5 Duration of the validity of the classification report

At the time the standard EN 13501-2: 2007 was published, no decision was made concerning the duration of validity of the classification document.

6 Warning

This classification document does not represent type approval or certification of the product.

Report	Name	Signature*	Date
Prepared by	P. TACK		16 JUL 2009
Reviewed by	Prof. dr. ir. P. VANDEVELDE	 io.	16 JUL 2009
* For and on behalf of WFRGENT N.V.			

EN 13501-2 FSG REC 017 -version 1

This document is the original version of this classification report and is written in English.

This report may be used only literally and completely for publications. - For publications of certain texts, in which this report is mentioned, our permission must be obtained in advance.

TEST REPORT N° 13437A

Grille 1

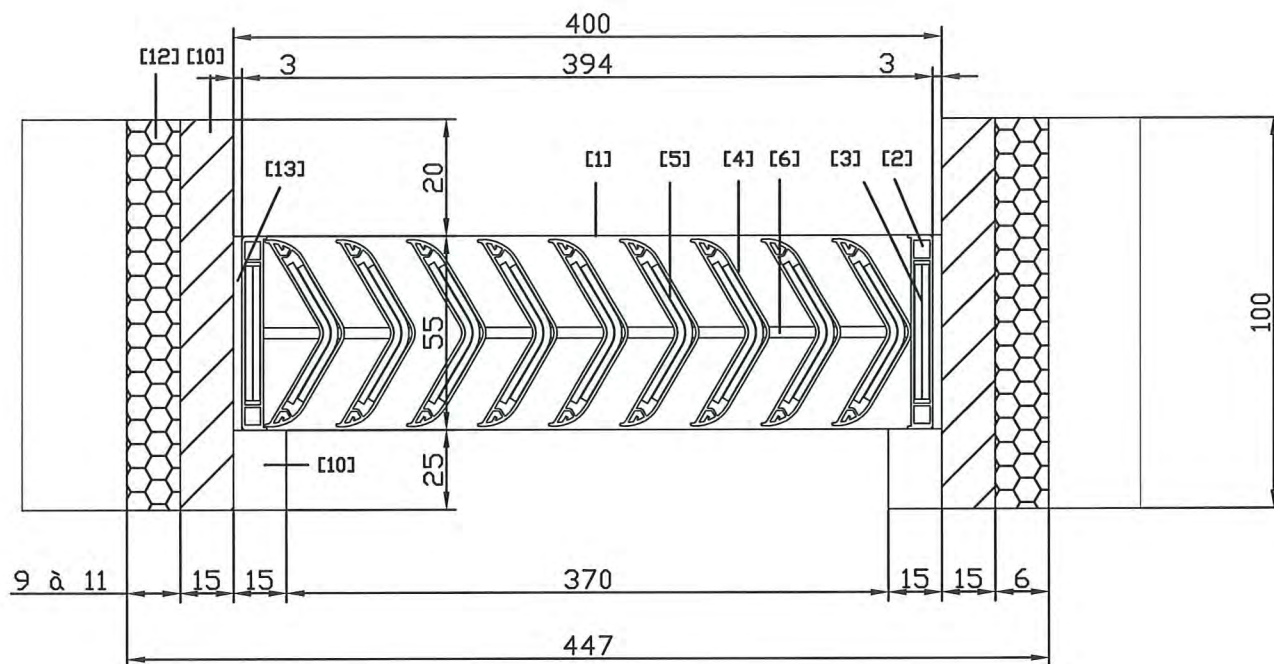

Exposed side

Grille 2

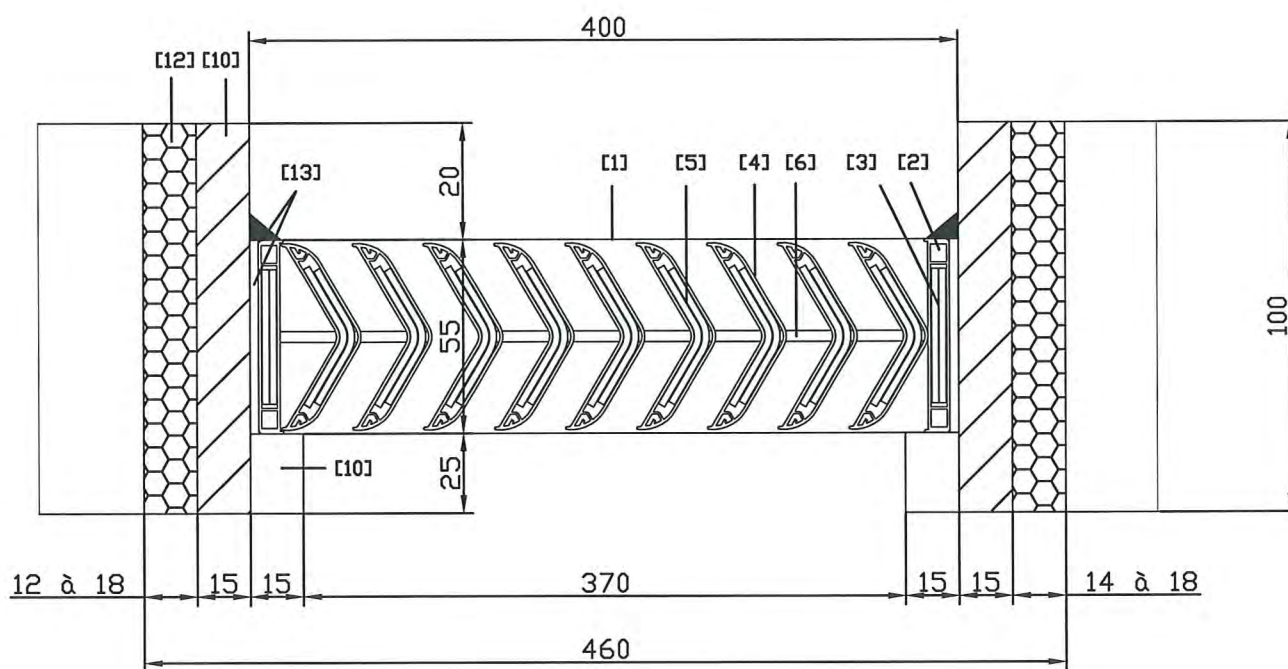

Grille 3

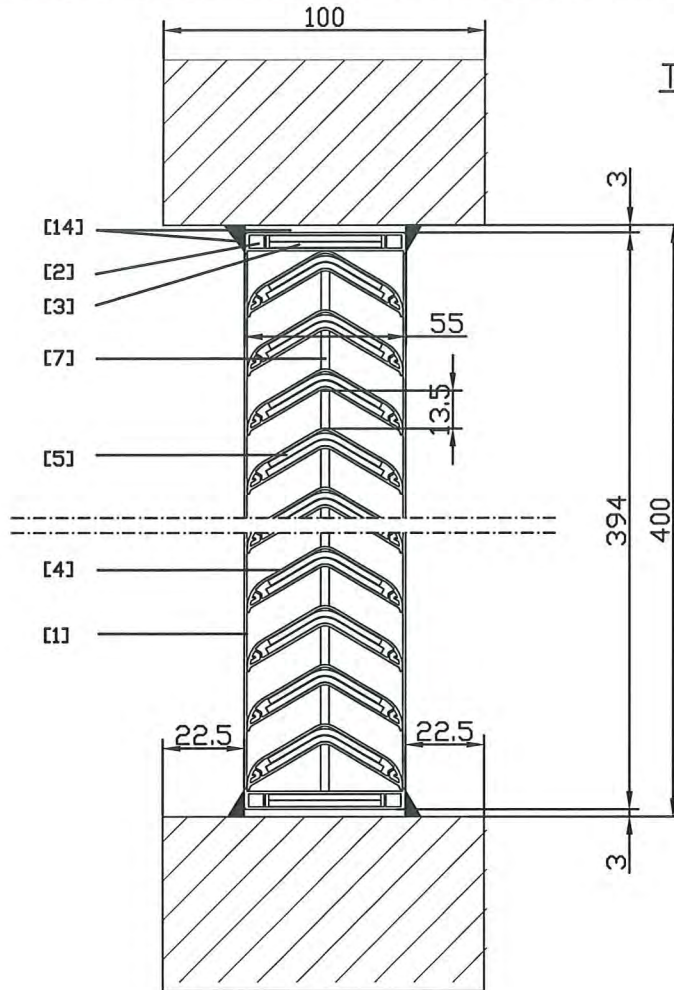

Exposed side

Grille 1

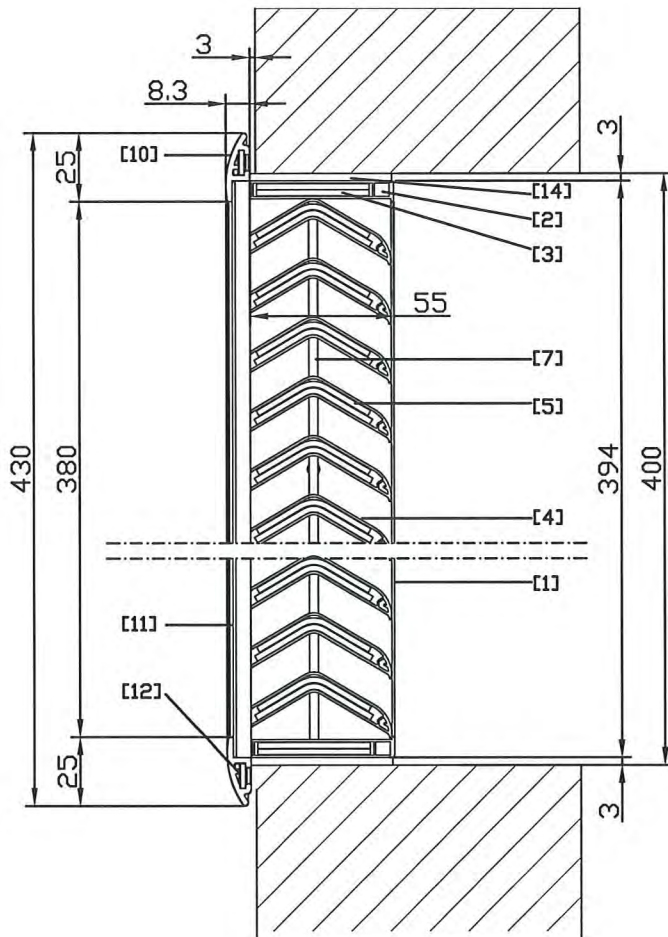

TEST REPORT N° 13439A

Grille 1

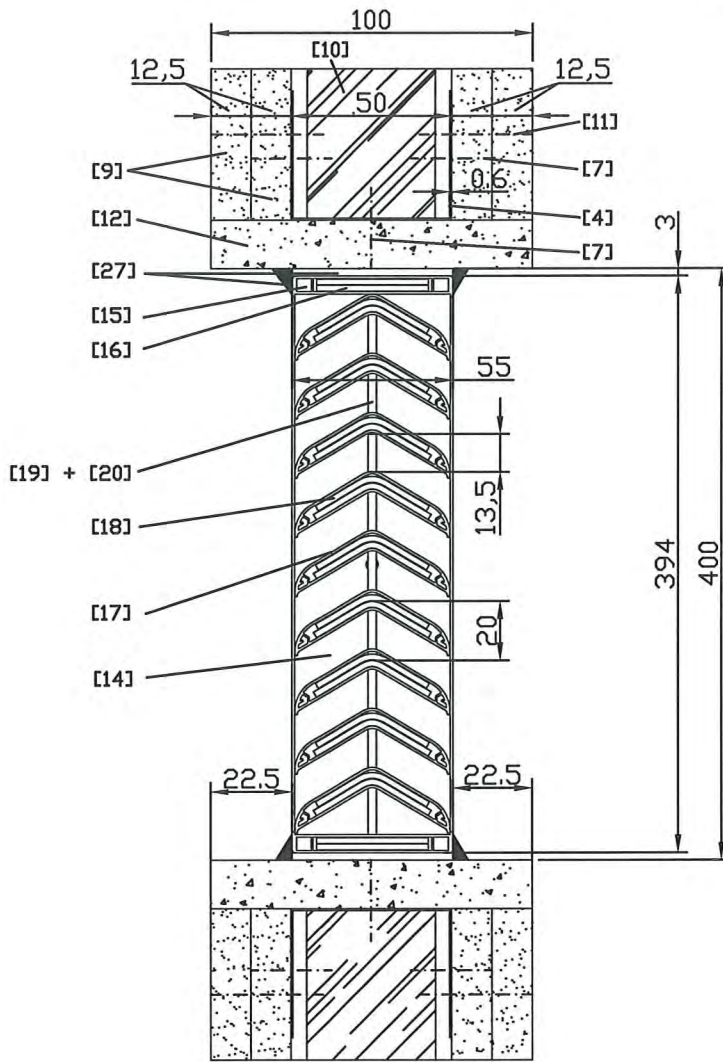

Exposed side

Grille 3

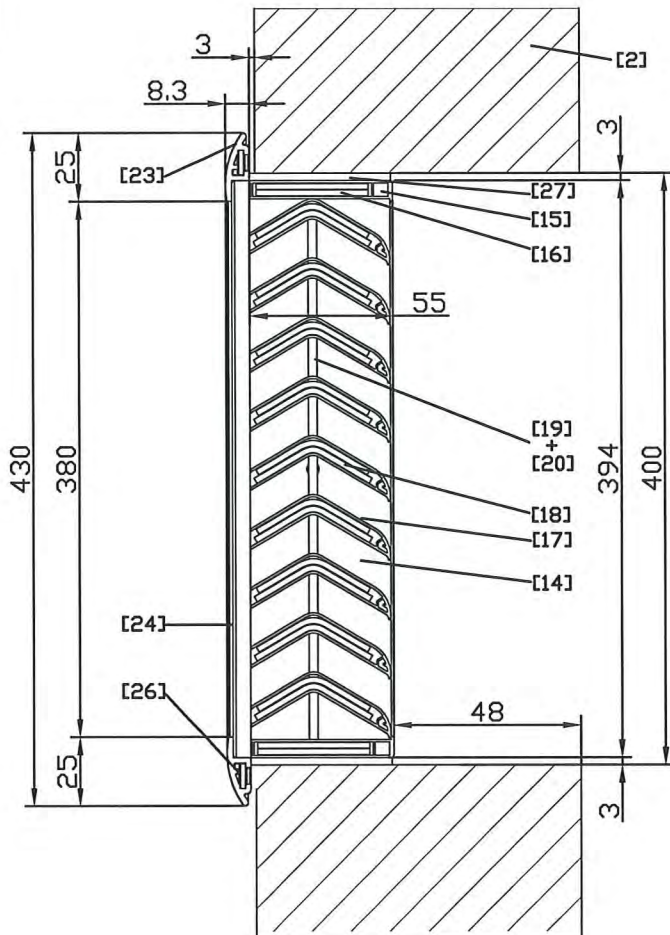

TEST REPORT N° 13440A

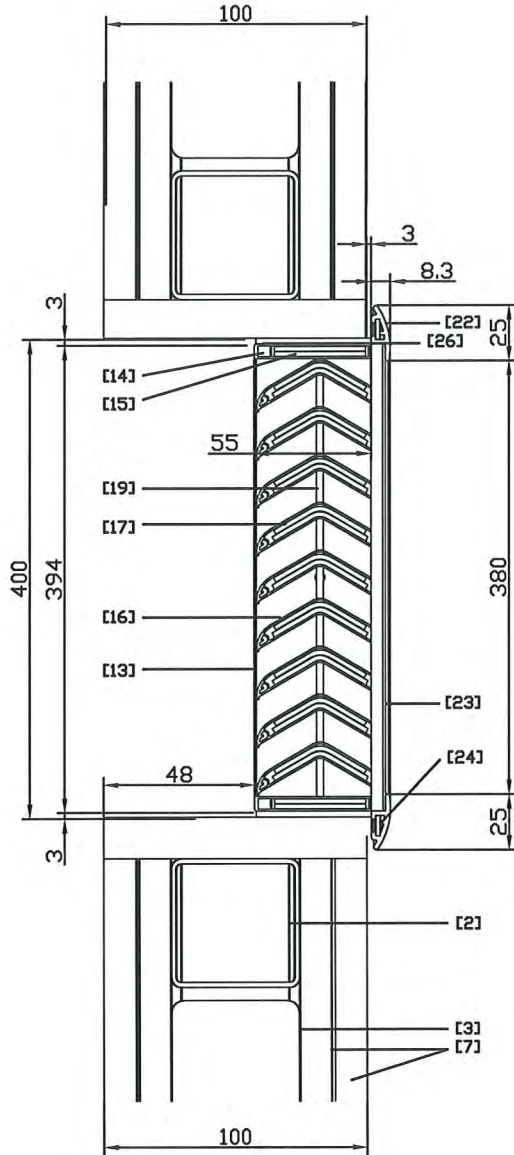

Grille 3

Exposed side

Grille 1

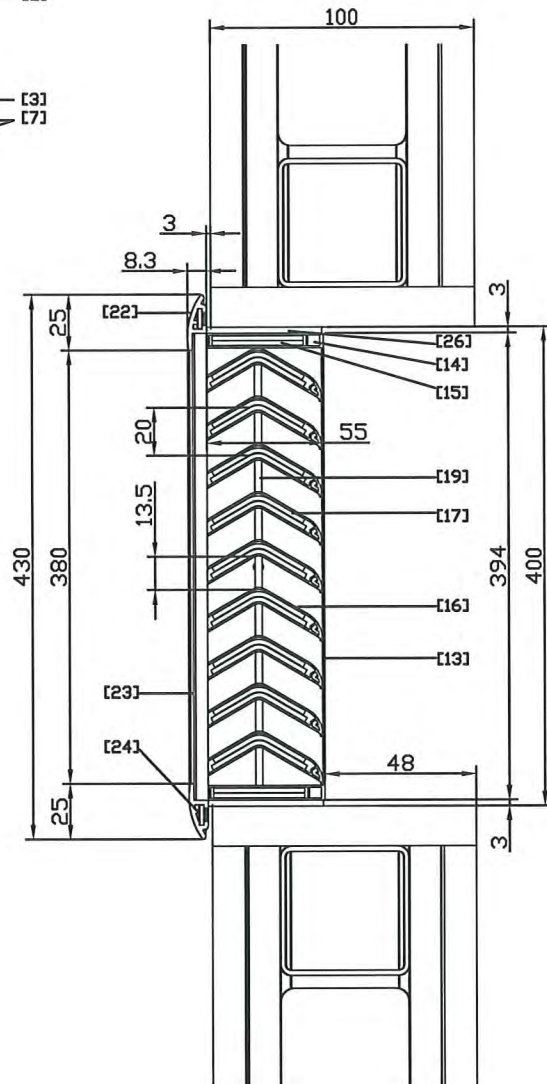

Exposed side

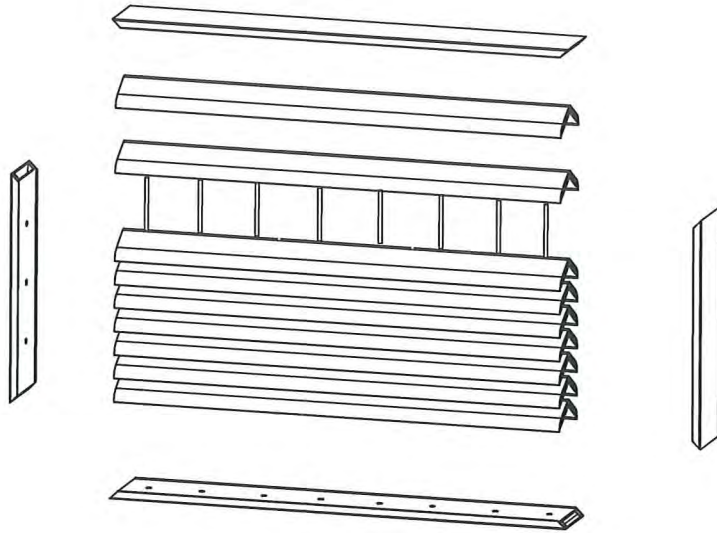

Horizontal intermediate slate

Corner bracket

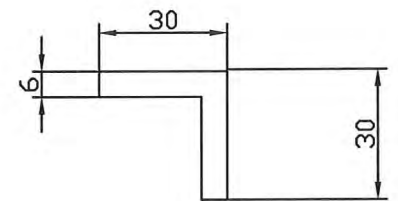
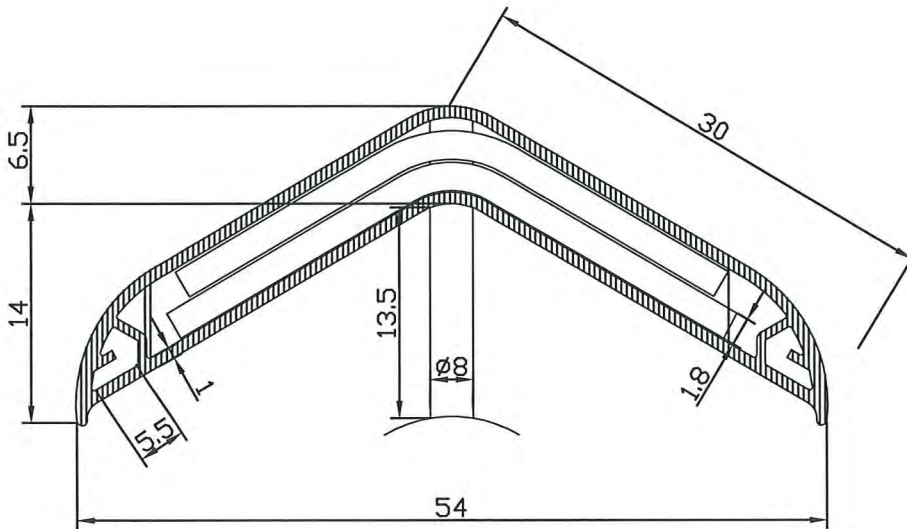

Corner bracket

Horizontal and vertical grille frame

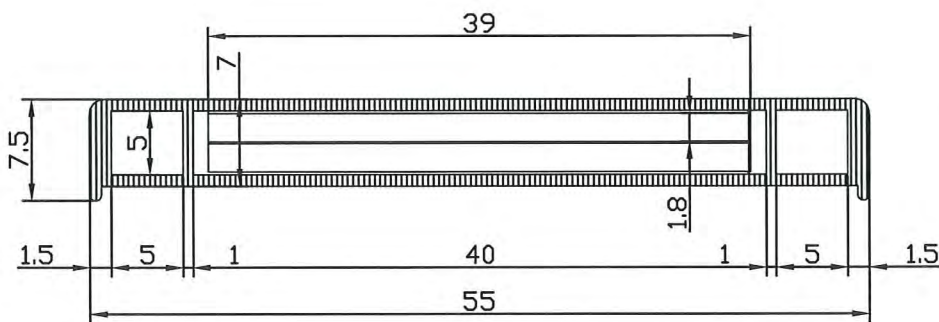
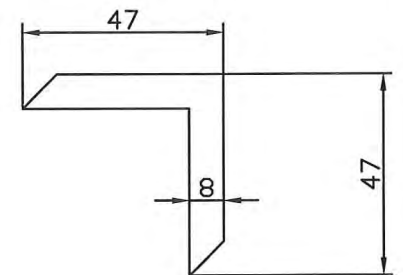

Cover plate profile

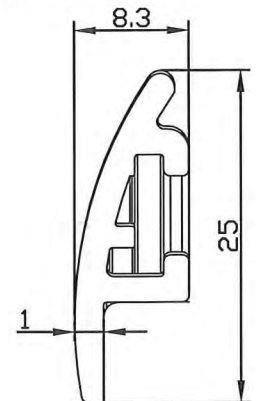

LEGEND

TEST REPORT N° 13437A

- [1] Vertical profiles – length: 394 mm – width: 55 mm – height: 7,5 mm – polystyrene cover – thickness cover: 1 mm.
- [2] Horizontal profiles – length: 794 mm – width: 55 mm – height: 7,5 mm – polystyrene cover – thickness cover: 1 mm.
- [3] Intumescent product – brand according to sponsor: PALUSOL 100 – width: 39 mm – length: 394 mm (vertical) or 794 mm (horizontal) – thickness: 1.8 mm.
- [4] Horizontal intermediate slates – dimensions of the section: 30 mm x 30 mm x 6,5 mm – length: 780 mm – polystyrene cover – thickness cover: 1 mm.
- [5] Intumescent product – brand according to sponsor PALUSOL 100 – width: 46 mm – length: 780 mm – thickness: 1.8 mm.
- [6] Steel bar – diameter: 4 mm – length: 398 mm.
- [7] Distance holder – polystyrene – outside diameter: 8 mm – wall thickness: 2 mm – length: 13.5 mm.
- [8] Corner bracket – polystyrene – dimensions of the section: 6 mm x 6 mm – dimensions: 30 mm x 30 mm.
- [9] Screw – galvanized steel – diameter: 2.6 mm – length: 20 mm.
- [10] Calcium silicate lath – brand: PROMATECT® – thickness: 15 mm – nominal volumetric mass: 870 kg/m³ (NV).
- [11] Screw – □ 6 x 90 mm
- [12] Mortar – brand and type: XELLA YTOREP – sealing mortar fire I.
- [13] Silicone mastic – brand and type: RF-TECHNOJOINT Mastic glue.

TEST REPORT N° 13438A

- [1] Vertical profiles – length: 394 mm – width: 55 mm – height: 7,5 mm – polystyrene cover – cover thickness: 1 mm.
- [2] Horizontal profiles – length: 795 mm – width: 55 mm – height: 7,5 mm – polystyrene cover – cover thickness: 1 mm.
- [3] Intumescent product – brand according to the sponsor: PALUSOL 100 – width: 39 mm – length: 394 mm (vertical) or 795 mm (horizontal) – thickness: 1.8 mm.
- [4] Horizontal intermediate slates – section dimensions: 30 mm x 30 mm x 6,5 mm – length: 780 mm – polystyrene cover – thickness cover: 1 mm.
- [5] Intumescent product – brand according to the sponsor PALUSOL 100 – width: 46 mm – length: 780 mm – thickness: 1.8 mm.
- [6] Steel bar – diameter: 4 mm – length: 398 mm.
- [7] Distance holder – polystyrene – outer diameter: 8 mm; length: 13,5 mm – wall thickness: 2 mm.
- [8] Corner bracket – polystyrene – section dimensions: 6 mm x 6 mm – dimensions: 30 mm x 30 mm.
- [9] Screw – galvanized steel – diameter: 2.6 mm – length: 20 mm.
- [10] Horizontal profile – polystyrene – length: 830 mm – width: 8.3 mm – height: 25 mm – wall thickness: 1 mm.
- [11] Vertical profile – polystyrene – length: 430 mm – width: 8.3 mm – wall thickness: 1 mm.
- [12] Corner bracket – aluminium – dimensions: 47 mm x 47 mm – width: 8 mm – thickness: 2 mm.
- [13] Glue – brand and type: LOCTITE 401.
- [14] Silicone mastic – brand and type: RF-TECHNOJOINT Mastic glue.

TEST REPORT N° 13439A

- [1] Air transfer grille – outer dimensions of the air transfer grille: 795 mm x 394 mm x 55 mm.
- [2] Wall – cellular concrete – width: 1500 mm; height: 3000 mm; thickness: 100 mm.
- [3] Flexible partition wall – width: 1500 mm; height: 3000 mm; thickness: 100 mm.
- [4] U-profile – galvanized steel – brand and type: LAFARGE NPH 50 – section dimensions: 40 mm x 50 mm x 40 mm – thickness: 0,6 mm.
- [5] Nail plug – steel – diameter: 6 mm; length: 40 mm.
- [6] C-profile – galvanized steel – brand and type: GYPROC Metal Stud MSV 50 – section dimensions: 6 mm x 48 mm x 50 mm x 51 mm x 6 mm – thickness: 0,6 mm.
- [7] Screw – steel – brand and type: BPB 25 – diameter: 3,5 mm, length: 25 mm.
- [8] Free edge – mineral wool.
- [9] Gypsum cardboard plate – brand and type: GYPROC ABA – thickness: 12,5 mm – surface mass: 9,1 kg/m² (NV).
- [10] Rock wool – brand and type: ROCKWOOL Rockfit adapt 431 – thickness: 40 mm – volume mass: 40 kg/m³ (NV).
- [11] Screw – steel – brand and type: BPB 35 – diameter: 3,5 mm, length: 35 mm.
- [12] Strip – calcium silicate – section dimensions: 15 mm x 100 mm – volume mass: 895 kg/m³ (MV).
- [13] Gypsum – brand and type: GYPROC Jointfiller.
- [14] Vertical profile – length: 394 mm; width: 55 mm; height: 7,5 mm – polystyrene cover – cover thickness: 1 mm.

- [15] Horizontal profile – length: 795 mm; width: 55 mm; height: 7,5 mm – polystyrene cover – cover thickness: 1 mm.
- [16] Intumescent product – brand according to the sponsor: PALUSOL 100 – width: 39 mm; length: 394 mm (vertical) of 795 mm (horizontal); thickness: 1,8 mm.
- [17] Horizontal intermediate slates – section dimensions: 30 mm x 30 mm x 6,5 mm – length: 780 mm – polystyrene cover – cover thickness: 1 mm.
- [18] Intumescent product – brand according to the sponsor: PALUSOL 100 – width: 46 mm; length: 780 mm; thickness: 1,8 mm.
- [19] Steel bar – diameter: 4 mm; length: 398 mm.
- [20] Distance holder – polystyrene – outer diameter: 8 mm; length: 13,5 mm – wall thickness: 2 mm.
- [21] Corner bracket – polystyrene – section dimensions: 6 mm x 6 mm – dimensions: 30 mm x 30 mm.
- [22] Screw – galvanized steel – diameter: 2,6 mm; length: 20 mm.
- [23] Horizontal profile – polystyrene – length: 830 mm; width: 8,3 mm; height: 25 mm – wall thickness: 1 mm.
- [24] Vertical profile – polystyrene – length: 430 mm; width: 8,3 mm; height: 25 mm – wall thickness: 1 mm.
- [25] Corner bracket – aluminium – dimensions: 47 mm x 47 mm – width: 8 mm – thickness: 2 mm.
- [26] Glue – brand and type: LOCTITE 401.
- [27] Silicone mastic – brand and type: RF-TECHNOJOINT Mastic glue.

TEST REPORT N° 13440A

- [1] U-profile – brand and type: PROFISTEEL[®] - section dimensions: 40 x 50 mm x 40 mm – thickness: 0.7 mm (MV)
- [2] Screw plug – brand and type: GYPROC screw plug SP 6/40 mm – with plug – diameter: 5.8 mm (MV) – total length: 39.6 mm (MV).
- [3] C-profile – MSV 50 – dimensions: 6 mm x 49 mm x 49 mm x 47 mm x 7 mm (MV) – thickness: 0.7 mm (MV).
- [4] self adhesive strip – mousse – width: 28 mm (MV) – thickness: 6 mm (MV).
- [5] Rock wool board – brand and type: ROCKFIT ADAPT 431 – 1000 mm x 600 mm – thickness: 40 mm – volume mass: 33 kg/m³ (MV).
- [6] Mineral wool – volume mass: 96 kg/m³ (NV).
- [7] Gypsum cardboard plate – brand and type: GYPROC ABA – thickness: 12.5 mm – volume mass: 406 kg/m³ (MV).
- [8] Screws – brand and type: self tapping screws BPB 25 – diameter: 3.5 mm – length: 25 mm.
- [9] Screws – brand and type: self tapping screws BPB 35 – diameter: 3.5 mm – length: 35 mm.
- [10] Joint filler – brand and type: BPB Gyproc JointFiller 45.
- [11] Joint strip – cardboard – width: 52.5 mm (MV).
- [12] Calcium silicate strip – thickness: 15 mm – width: 100 mm – volume mass: 895 kg/m³ (MV).
- [13] Vertical profiles – polystyrene – length: 394 mm – width: 55 mm – height: 7,5 mm – thickness: 1 mm.
- [14] Horizontal profiles – polystyrene – length: 795 mm – width: 55 mm – height: 7,5 mm – thickness: 1 mm.

- [15] Intumescent product – brand according to the sponsor: PALUSOL 100 – width: 39 mm – length: 394 mm (vertical) of 795 mm (horizontal) – thickness: 1.8 mm.
- [16] horizontal Intermediate slates – polystyrene – section dimensions: 30 mm x 30 mm x 6,5 mm – length: 780 mm – thickness: 1 mm.
- [17] Intumescent product – brand according to the sponsor PALUSOL 100 – width: 46 mm – length: 780 mm – thickness: 1.8 mm.
- [18] Steel bar – diameter: 4 mm – length: 398 mm.
- [19] Distance holder – polystyrene – outer diameter: 8 mm; length: 13,5 mm – wall thickness: 2 mm.
- [20] Corner bracket – polystyrene – section dimensions: 6 mm x 6 mm – dimensions: 30 mm x 30 mm.
- [21] Screw – galvanized steel – diameter: 2.6 mm – length: 20 mm.
- [22] Horizontal profile – polystyrene – length: 830 mm – width: 8.3 mm – height: 25 mm – thickness: 1 mm.
- [23] Vertical profile – polystyrene – length: 430 mm – width: 8.3 mm – thickness: 1 mm.
- [24] Corner bracket – aluminium – dimensions: 47 mm x 47 mm – width: 8 mm – thickness: 2 mm.
- [25] Glue – brand and type: LOCTITE 401.
- [26] Silicone mastic – brand and type: RF-TECHNOJOINT Mastic glue.