



## **CLASSIFICATION REPORT n° EFR-19-005414 - Revision 2**

According to standards EN 15650: 2010 and EN 13501-3: 2007

---

<b>Reference Laboratory assessment</b>	EFR-19-005414 - Revision 2
<b>Regarding</b>	A range of "CU-LT"-type fire dampers Operating vacuum pressure: -300 / -500 Pa
<b>Sponsor</b>	RF TECHNOLOGIES Lange Ambachtstraat, 40 B - 9860 OOSTERZELE

**This classification report supersedes classification report EFR-19-005414 - Revision 1.**

**CHANGE HISTORY**

Revision level	Date	Changes	Author
0	15/01/2020	Document creation	RST
1	12/07/2021	<ul style="list-style-type: none"><li>- Installation in a flexible partition wall with a mortar seal</li><li>- Installation in a 200mm-thick aerated concrete wall</li><li>- Update of the field of direct application of test results</li></ul>	CSC
2	23/08/2021	<ul style="list-style-type: none"><li>- Correction of the classification for the installation in a flexible partition wall with a mortar seal</li></ul>	CSC

## 1. INTRODUCTION

---

This classification report defines the classification assigned to a range of "CU-LT"-type fire dampers in accordance with the procedures set out in the standard EN 13501-3: 2007 "Fire classification of construction products and building elements – Part 3: Classification using data from fire resistance tests, on products and elements used in building service installations: fire resisting ducts and fire dampers" and in the standard EN 15650: 2010 "Ventilation for buildings. Fire dampers".

## 2. BODY

---

Efectis France  
Voie Romaine  
F - 57280 MAIZIERES-LES-METZ

Notified body: 1812

## 3. SPONSOR

---

RF TECHNOLOGIES  
Lange Ambachtstraat, 40  
B - 9860 OOSTERZELE

## 4. REFERENCE TEST

---

- 08 - E - 442 (EFFECTIS France)
- 13576A (WFRGENT)
- 3521 (TÜM)
- 09 - H - 362 (EFFECTIS France)
- 13 - E - 500 (EFFECTIS France)
- 13 - G - 514 (EFFECTIS France)
- 13 - H - 612 (EFFECTIS France)
- 13 - U - 544 (EFFECTIS France)
- 14 - E - 253 (EFFECTIS France)
- 13992A (WFRGENT)
- 13992B (WFRGENT)
- 13576A (WFRGENT)
- 20558A (WFRGENT)
- EFR-16-J-000352

## 5. REFERENCE AND ORIGIN OF THE TEST SPECIMENS

---

Reference: CU-LT

Origin: RF TECHNOLOGIES  
Lange Ambachtstraat, 40  
B - 9860 OOSTERZELE

## 6. OVERALL PRINCIPLE

---

### 6.1. TYPE OF FUNCTION

The "CU-LT"-type damper is defined as a "fire damper". Its function is to be fire-resistant as regards fire integrity, thermal insulation and leakage flow rates.

### 6.2. GENERAL

Each fire damper is composed of a tunnel, within which a horizontally- or vertically-mounted mobile blade pivots using an external mechanism and a transmission.

Approved fire dampers have flow cross-section dimensions of between 200 x Ø 100mm and 800 x Ø 600mm (w x h).

### 6.3. DETAILED DESCRIPTION OF THE ELEMENTS

#### 6.3.1. Fire damper casing

Each fire damper is composed of a galvanised steel duct with (W-6) x (H-6) mm, 0.8mm thick and 300mm long.

At each end, the fire damper's tunnel is fitted with a steel flange. At each corner, the flanges are fixed together in pairs using a steel bracket attached to each flange by two aluminium rivets (Ø 4.8mm).

Level with the fire damper blade, the circumference of the casing was perforated with 20 x 3mm holes, at 3mm intervals over a width of 9mm.

On the inside, the perforations are completely covered by graphite, self-adhesive, intumescent tape with dimensions of 44 x 2mm (RECTORSEAL). A 60mm-wide strip of self-adhesive PP (TESA) tape is placed on the intumescent tape.

To guarantee its stiffness, the tunnel's sheet metal is bent over along the perforations described above at a height of 20mm. These bends act as reinforcement.

Inside the tunnel, EPDM-type gasket seals are placed on the semi-periphery above and below the damper blade.

Four brackets are used, in pairs, to hold the metal plates described above in place. They are fixed using two aluminium rivets (Ø 4.8mm) on each plate. Each of the brackets has a steel lug which can be bent in order to demarcate the seal limit.

Halfway up, the fire damper casing has two openings (Ø 12mm and Ø 18mm) on the mechanism side, which allow the hinge pin of the fire damper blade to pass through, and five openings (Ø 5mm), which are used to fix the transmission housing using aluminium rivets (Ø 4.8mm).

#### 6.3.2. Blade

The blade is made of a 25mm-thick Promatect H plate.

On the outer edge of the blade, a groove with dimensions of 15 x 2mm (w x d) is machined.

Two galvanized steel hinge pin brackets, with cross section dimensions of 80 x 40mm are fixed on the blade using two bolt (M5 x 30mm). The pin is fixed to the brackets using two bolts (M5 x 16mm).

The blade pivots on a steel hinge pin, with cross section dimensions of 10 x 10mm.

The pin rests on two brass bearings (Ø 12 x 14.5mm and Ø 18 x 9.5mm) on the mechanism side, fitted in the fire damper casing.

The clearance between the blade and the fire damper casing is approximately 4mm.

### 6.3.3. Mechanism

The control mechanism is fully installed on the outside of the fire damper and is composed of the following elements:

- A BLF (BELIMO) actuator
- A mounting section
- A transmission mechanism
- A thermal fuse

The actuator is connected to the protruding pin of the transmission housing and is fixed using two bolts (M6 x 70mm) to a 2mm-thick steel section.

The mounting section is fixed to the fire damper casing using two aluminium rivets (Ø 4.8mm). A transmission mechanism is installed between the mounting section and the fire damper casing using four aluminium rivets (Ø 4.8mm). This mechanism is protected by a plastic sheathing.

A thermal seal is fixed to the fire damper casing using a plastic bracket fixed using a single blind rivet (Ø 4.8mm). The thermal seal is fixed to this bracket using two steel screws (Ø 3.5mm). The fuse connected to the thermal seal is located on the inside of the fire damper casing.

When switched on, the actuator puts the blade in the open position. An internal torsion spring is compressed at the same time.

If there is a power cut or the fuse is activated, the internal spring shuts the fire damper.

## 7. INSTALLATION OF THE TEST SPECIMENS

---

The classification obtained for standard installation in the various construction elements and their respective sealing remain valid for fire dampers installed with horizontal or vertical axis, with a minimal space:

- of 50mm between fire dampers installed in separate ducts;
- of 50mm between the fire damper and a construction element (wall);
- of 25mm between the fire damper and a construction element (floor).

A maximum of two rectangular dampers may be installed at a minimum distance from one another, vertically and horizontally (with a group of four dampers at most).

-

Sealing between the fire dampers:

- For a space  $\geq 50$ mm:
  - o density = 150kg/m<sup>3</sup>, thermal conductivity  $\lambda = 0.041$ W/mK at 50°C and water vapour absorption = 0.02%, Euroclass A1,
  - o total width : minimum 400mm whose 150mm on the side of the mechanism and flush or protruding on the opposite side,

Sealing between the fire damper(s) and the supporting construction (wall or floor) must be performed using stone wool with following characteristics:

- For a space  $\geq 50$ mm:
  - o density = 150kg/m<sup>3</sup>, thermal conductivity  $\lambda = 0.041$ W/mK at 50°C and water vapour absorption = 0.02%, Euroclass A1,
  - o total width : minimum 400mm whose 150mm on the side of the mechanism and flush or protruding on the opposite side,

- For a space < 50mm:
  - o compressed stone wool with a density after compression of minimum 67kg/m<sup>3</sup> (e.g. : rockwool ROCKFIT 431 (ROCKWOLL) with density of 40kg/m<sup>3</sup> and thickness of 40mm compressed to 25mm,
  - o total width : minimum 400mm whose 150mm on the side of the mechanism and flush or protruding on the opposite side.

### **7.1. INSTALLATION IN A 100MM-THICK AERATED CONCRETE WALL**

The fire damper is installed in feed-through in a 100mm-thick aerated concrete wall with a density of 550kg/m<sup>3</sup>.

The fire damper is positioned in an opening with dimensions (W + 100) x (H + 100) mm. The fire damper is then sealed with standard mortar or plaster.

The fire damper can also be sealed using the following types of plaster:

- LAFARGE DELTA (LAFARGE)
- GOLDBAND (KNAUF)
- GYPROC ILPX Plus (BPB)

The fire damper is placed in such a way that the fire damper's mounting lug is flush with the wall surface. The mounting lug can also be bent over and therefore not be involved in sealing the fire damper. In this case, the fire damper is positioned so that the mechanism is flush with the surface of the supporting construction.

The hinge pin of the blade may be horizontally- or vertically-mounted.

### **7.2. INSTALLATION IN A 200MM-THICK AERATED CONCRETE WALL**

The fire damper is installed in feed-through in a 200mm-thick aerated concrete wall with a density of 450kg/m<sup>3</sup>.

The fire damper is positioned in an opening with dimensions (W + 100) x (H + 100)mm. The fire damper is then sealed with standard mortar or plaster.

The fire damper can also be sealed using the following types of plaster:

- LAFARGE DELTA (LAFARGE)
- GOLDBAND (KNAUF)
- GYPROC ILPX Plus (BPB)

The fire damper is placed in such a way that the fire damper's mounting lug is flush with the wall surface. The mounting lug can also be bent over and therefore not be involved in sealing the fire damper. In this case, the fire damper is positioned so that the mechanism is flush with the surface of the supporting construction.

The hinge pin of the blade may be horizontally- or vertically-mounted.

### **7.3. INSTALLATION IN A 110MM-THICK REINFORCED CONCRETE FLOOR**

The fire damper is installed in feed-through in a 110mm-thick reinforced concrete floor with a density of 2200kg/m<sup>3</sup>.

The fire damper is positioned in an opening with dimensions (W + 100) x (H + 100)mm. The fire damper is then sealed with standard mortar.

The fire damper is placed in such a way that the fire damper's mounting lug is flush with the floor surface. The mounting lug can also be bent over and therefore not be involved in sealing the fire damper. In this case, the fire damper is positioned so that the mechanism is flush with the surface of the supporting construction.

#### 7.4. INSTALLATION IN A 150MM-THICK AERATED/REINFORCED CONCRETE FLOOR

Fire dampers from the CU-LT range can be sealed using plaster in an aerated/reinforced concrete floor with a minimum thickness of 150mm and a minimum density of 650/2200kg/m<sup>3</sup>.

The opening for a fire damper has dimensions (W + 100) x (H + 100)mm.

The fire damper can also be sealed using the following types of plaster:

- LAFARGE DELTA (LAFARGE)
- GOLDBAND (KNAUF)
- GYPROC ILPX Plus (BPB)

The fire damper is placed in such a way that the fire damper's mounting lug is flush with the floor surface. The mounting lug can also be bent over and therefore not be involved in sealing the fire damper. In this case, the fire damper is positioned so that the mechanism is flush with the surface of the supporting construction.

#### 7.5. INSTALLATION OF FIRE DAMPERS IN A BA13, BA18 OR BA25 GYPSUM PLASTERBOARD PARTITION

- Partition

The fire dampers are installed in a "D 98/48"-type partition.

This partition is made using a metal framework fitted with twin-layer facings with type A or type F gypsum plasterboard; the partition has an overall thickness of 98mm, with an internal cavity of 48mm filled with stone wool.

- Outer framework

The outer framework is made using 6/10mm-thick galvanised steel MSH 50 rails, fixed to the concrete support frame with steel screws (Ø 6mm) and anchors (Ø 6mm), spaced at intervals of 800mm.

- Central framework

The framework of the partition is made using single, 6/10mm-thick galvanised steel MSV 50 studs, slotted into the upper and lower rails and screwed at the base with a centre-to-centre distance of 600mm. A thermal expansion gap of approximately 5mm is left at the top of each stud.

- Header joist

A header joist designed to allow the fire damper to pass through is made using MSV 50 studs and MSH 50 rails.

The header joist is made of:

- A stud added to the central framework of the partition spaced (L + 65)mm from the stud [or (L + 100)mm, for plaster sealing] belonging to the central framework and acting as a second support stud for the weight of the fire damper itself;
- An R 48 horizontal rail, sheared and bent, and installed perpendicular to the additional studs at the top and bottom and spaced (H + 65)mm [or (H + 100)mm for plaster sealing] apart from one another.
- For fire dampers with a length (L + 65)mm [or (L + 100)mm for plaster sealing] greater than 600mm, the stud belonging to the central framework is interrupted for the installation of the header joist.

The various elements are fixed together using screws (Ø 3.5mm).

- Facings

Solution 1:

The partition is made using 12.5mm-thick GYPROC Rf-type plasterboards with a density of 750kg/m<sup>3</sup>. The facings can also be made using BA18 or BA25 plasterboard panels provided the reports (*procès-verbaux*) associated with the partitions made using these panels show that they meet the EI 120 fire resistance criterion.

For BA 13 panels, the plasterboard is installed with the vertical joints of one facing offset in relation to the other within the same facing and also between the inner surfaces of both facings.

The vertical joints of the plasterboards are perpendicular to the studs. The plasterboards are fixed to the framework with 212/25-type self-drilling screws spaced at intervals of 500mm for the first layer and 212/35-type screws at intervals of 300mm for the second layer.

The visible joints between the plasterboards and the screeds with concrete frame are treated using the JOINTFILLER filler + jointing tape technique. The screw heads are also concealed with the same filler.

The cavity between the plasterboards is filled with ROCKFIT 431-type stone wool with a density of 33kg/m<sup>3</sup>.

Solution 2:

This twin-layer facing can be replaced by 2 x type F BA 13 twin-layer facing.

The facings are made using a twin layer of BA 13 plasterboard. The plasterboards have a maximum width of 600mm.

The plasterboards are fixed to all of the steel sheet studs using TTPC 35 screws spaced at average intervals of 250mm.

The joints between the plasterboards are treated with plaster filler, in which a 52mm-wide strip of micro-perforated jointing tape is smoothly applied.

The screeds and screw heads are treated with plaster filler.

- Sealing around the fire damper

Solution 1:

The space between the tunnel of the fire damper and the wall is approximately 30mm. A 12.5mm-thick strip of plaster reinforced with RINOFLAM-type glass wool, with a density of 850kg/m<sup>3</sup>, wrapped around the fire damper, is fixed to the wall every 250mm using self-drilling steel M6 screws above this space. All the joints between the plasterboard are covered with BPB GYPROC Jointfiller 45-type filler.

The screws are also covered with the same type of filler.

Solution 2:

On both the fire side and the opposite to fire side, the clearance between the fire damper's tunnel and the opening is plugged with standard plaster.

## 7.6. INSTALLATION OF THE OFFSET FIRE DAMPERS

### **For the offset installation of 100mm-thick aerated concrete wall with a duct made using sheet metal and protected by GEOFLAM 45, GEOFLAM F LIGHT 35 plates:**

The CU-LT fire damper was installed offset, inside or outside the furnace, on a galvanised steel sheet service duct.

The length of this duct is not specified. If the duct length is greater than 1m, a supporting system will be implemented as described above, at intervals of 1m, as well as additional support level with the fire damper.



The fire damper was fixed to the duct using 10 x 118 x 20mm bolts. See drawing in the appendix.

- Protection of the duct and fire damper.

The service duct was covered with 35mm-thick staff plates, reference GEOFLAM F LIGHT or 45mm-thick staff Geoflam F plates, fixed together using glue and packing. The fire damper casing was therefore also protected over a length of 120mm.

The GEOFLAM F, GEOFLAM F LIGHT staff plate protection was introduced between the fire damper and the wall. It stopped 15mm from the wall. The free space between the wall and the staff plate protection was filled by packing (a mix of plaster and fibrous material).

- Sealing

The opening, with dimensions (W + 100) x (H + 100) mm and made in the 100mm-thick aerated concrete wall, was filled with standard mortar (reference CEM II/B-V-32.5N manufactured by CBR-Heidelberg)

- Duct support system

The hangers were composed of 8mm diameter threaded rods and supporting rails with dimensions of 25 x 25 x 2mm and 1m long. A distance of approximately 25mm was kept between the threaded rods and the vertical sides of the duct.

The threaded rods were protected by staff half-shells (Ø 90mm) and held together using adhesive and packing. The crossmember was protected with a "U"-shaped protective section in plaster (100 x 60mm), glued to the underside of the duct with PLACOL (PLACO SAINT-GOBAIN) or GEOCOL (GEOSTAFF) type adhesive plaster.

**For the offset installation of 100mm-thick aerated concrete wall with a duct made using GEOFLAM 45, GEOFLAM F LIGHT 35 plates:**

The CU-LT fire damper was installed offset, inside or outside the furnace, on a GEOFLAM F 45, GEOFLAM F LIGHT 35 plate service duct.

The length of this duct is not specified. If the duct length is greater than 1m, a supporting system will be implemented as described above, at intervals of 1m, as well as additional support level with the fire damper.

- Protection of the duct and fire damper

The service duct was made with 45mm-thick Geoflam F staff plates, 35mm-thick GEOFLAM F LIGHT staff plates, fixed together using glue and packing. The fire damper casing was therefore also protected over a length of 120mm.

The GEOFLAM F, GEOFLAM F LIGHT staff plate protection was introduced between the fire damper and the wall. It stopped 15mm from the wall. The free space between the wall and the staff plate protection was filled by packing (a mix of plaster and fibrous material).

- Sealing

The opening, with dimensions (W + 100) x (H + 100) mm and made in the 100mm-thick aerated concrete wall, was filled with standard mortar (reference CEM II/B-V-32.5N manufactured by CBR-Heidelberg)

- Duct support system

The hangers were composed of 8mm diameter threaded rods and supporting rails with dimensions of 25 x 25 x 2mm and 1m long. A distance of approximately 25mm was kept between the threaded rods and the vertical sides of the duct.

The threaded rods were protected by staff half-shells (Ø 90mm) and held together using adhesive and packing. The crossmember was protected with a "U"-shaped protective section in plaster (100 x 60mm), glued to the underside of the duct with PLACOL (PLACO SAINT-GOBAIN) or GEOCOL (GEOSTAFF) type adhesive plaster.

**For the offset installation of a 100mm-thick aerated concrete wall or a 100mm-thick gypsum plasterboard partition with a duct made using sheet metal and protected by stone wool panels for EI 60 performance:**

The CU-LT fire damper + IFW Kit was installed offset, inside or outside the furnace, on a galvanised steel sheet service duct.

The length of this duct is not specified. If the duct length is greater than 1500mm, a supporting system will be implemented as described above, at intervals of 1500mm, as well as additional support level with the fire damper.

The fire damper was fixed to the duct using 10 x 118 x 20mm bolts.

See drawing in the appendix.

- Protection of the duct and fire damper

The service duct was covered with :

- 60mm-thick Promastop CB, type stone wool panels, fixed to the duct using screws (Ø 5 x 90mm) and washers (M6 x 44mm). The fire damper casing was therefore also protected over a length of 150mm

Or

- 2 x 50 mm Promastop CB ou Promastop CB-CC 50 or HILTI-CFS-CT\_B\_1s-type stone wool panels fixed to the duct using screws (Ø 5 x 90mm) and washers (M6 x 44mm). The fire damper casing was therefore also protected over a length of 150mm.

The joints between the panels, the screws and the support washers were covered with a filler coating:

- Promastop E for Promastop CB
- Promastop CC for Promastop CB-CC
- Hilti CFS-S ACR for Hilti CFS-CT B

- Sealing

**Aerated concrete wall or gypsum plasterboard partition:**

The opening, with dimensions (W + 600) x (H + 600) mm and made in the 100mm-thick aerated concrete wall or a 100mm-thick gypsum plasterboard partition, was filled with:

- A layer of 60mm-thick Promastop CB, Promastop CB-CC 60 or HILTI-CFS-CT\_B\_1s-type stone wool panels, covered on both sides with a filler coating:
  - o Promastop E for Promastop CB

Or

- Two layers of 50mm-thick Promastop CB type stone wool panels, covered on both sides with a filler coating:
  - o Promastop E for Promastop CB
  - o Promastop CC for Promastop CB-CC
  - o Hilti CFS-S ACR for Hilti CFS-CT B

The

- Promastop E for Promastop CB
- Promastop CC for Promastop CB-CC
- Hilti CFS-S ACR for Hilti CFS-CT B

filler was also applied to the joints between the stone wool panels and on the joints between the stone wool panels and the supporting construction (the surface was already pre-coated).

**Aerated concrete wall only:**

The opening, with dimensions (W + 100) x (H + 100) mm and made in the 100mm-thick aerated concrete wall, is filled with standard mortar (reference CEM II/B-V-32.5N manufactured by CBR-Heidelberg).

- Duct support system

The hangers were composed of 8mm diameter threaded rods and supporting rails with dimensions of 35 x 35 x 2mm and 1m long. A distance of approximately 25mm was kept between the threaded rods and the vertical sides of the stone wool inner panel.

The threaded rods and the rail were not protected.

The hangers are located at the joint between the duct and the fire damper, approximately 1800mm from the wall.

**For the offset installation of a 100mm-thick aerated concrete wall or a 100mm-thick gypsum plasterboard partition with a duct made using sheet metal and protected by stone wool panels for EI 90 performance:**

The CU-LT fire damper + IFW Kit was installed offset, inside or outside the furnace, on a galvanised steel sheet service duct.

The length of this duct is not specified. If the duct length is greater than 1500mm, a supporting system will be implemented as described above, at intervals of 1500mm, as well as additional support level with the fire damper.

The fire damper was fixed to the duct using 10 x 118 x 20mm bolts.  
See drawing in the appendix.

- Protection of the duct and fire damper

The service duct was covered with two layers of 50mm-thick Promastop CB, Promastop CB-CC 50 or HILTI-CFS-CT\_B\_1s-type stone wool panels or one layer of 80mm-thick Promastop CB, Promastop CB-CC 80 or HILTI-CFS-CT\_B\_1s-type stone wool panels, fixed to the duct using screws (Ø 5 x 120mm) and washers (M6 x 44mm). The fire damper casing was therefore also protected over a length of 150mm.

The joints between the panels, the screws and the support washers were covered with a filler coating:

- Promastop E for Promastop CB
- Promastop CC for Promastop CB-CC
- Hilti CFS-S ACR for Hilti CFS-CT B

- Sealing

**Aerated concrete wall or gypsum plasterboard partition:**

The opening, with dimensions (W + 600) x (H + 600) mm and made in the 100mm-thick aerated concrete wall or a 100mm-thick gypsum plasterboard partition, was filled with:

- Two layers of 50mm-thick Promastop CB, Promastop CB-CC 50 or HILTI-CFS-CT\_B\_1s-type stone wool panels, covered on one side with a filler coating:
  - o Promastop E for Promastop CB
  - o Promastop CC for Promastop CB-CC
  - o Hilti CFS-S ACR for Hilti CFS-CT B
- A layer of 80mm-thick Promastop CB, Promastop CB-CC 80 or HILTI-CFS-CT\_B\_1s-type stone wool panels, covered on both sides with a filler coating:
  - o Promastop E for Promastop CB
  - o Promastop CC for Promastop CB-CC
  - o Hilti CFS-S ACR for Hilti CFS-CT B

The

- Promastop E for Promastop CB
- Promastop CC for Promastop CB-CC
- Hilti CFS-S ACR for Hilti CFS-CT B

filler was also applied to the joints between the stone wool panels and on the joints between the stone wool panels and the supporting construction (the surface was already pre-coated).

**Aerated concrete wall only:**

The opening, with dimensions (W + 100) x (H + 100) mm and made in the 100mm-thick aerated concrete wall, is filled with standard mortar (reference CEM II/B-V-32.5N manufactured by CBR-Heidelberg).

- Duct support system

The hangers were composed of 8mm diameter threaded rods and supporting rails with dimensions of 50 x 38 x 5mm and 1m long. A distance of approximately 25mm was kept between the threaded rods and the vertical sides of the stone wool inner panel.

The threaded rods and the rail were not protected.

The hangers are located at the joint between the duct and the fire damper, approximately 1800mm from the wall.

## 7.7. INSTALLATION IN A FLEXIBLE PARTITION WALL WITH A MORTAR SEAL

### 7.7.1. Flexible partition wall

The standard flexible wall consists of U and C profiles of width 50mm which are covered by two layers of gypsum boards KNAUF DF of thickness 12.5mm and density 816.4kg/m<sup>3</sup> on both sides. The vertical joints are staggered between the layers of gypsum boards. The flexible wall is insulated with ROCKWOOL ROCKFIT MONO NEW of thickness 40mm and density 35kg/m<sup>3</sup>.

The partition wall has a total thickness of 100mm.

The installation opening in the partition wall has for dimensions (W + 62) x (H + 62)mm.

### 7.7.2. Penetration seal

The damper is sealed into the opening of the flexible partition wall with HOLCIM CLASSIC CEM II/B-M 32.5N mortar of density 1773.9kg/m<sup>3</sup> on a section of 50 x 100mm (w x th). The composition of the mortar is 2 units sandy clay + 1 unit sand + 1 unit cement and water.

The axis of the damper is positioned horizontally.

## 8. FIRE RESISTANCE CLASSIFICATIONS

### 8.1. CLASSIFICATION REFERENCE

This classification procedure was conducted in accordance with section 7.2.4 of the standard EN 13501-3.

### 8.2. CLASSIFICATIONS

The elements are classified according to the following combinations of performance parameters and classes for the following supporting constructions.

The dimensional range\* covered by the performances stated below is as follows:

	200	250	300	350	400	450	500	550	600	650	700	750	800
100													
150													
200													
250													
300													
350													
400													
450													
500													
550													
600													

\* Interval of 50mm provided for information only.

- Fire dampers installed with IFW installation kit with plaster sealing in a light partition made using 98/48 type A (EN520) gypsum plasterboard panels.

No other classification is authorised.

E	I		t		ve	-	ho	-	i	↔	o	-	S
<b>E</b>	<b>I</b>		<b>60</b>		<b>ve</b>	-		-	<b>i</b>	↔	<b>o</b>	-	<b>S</b>

- Fire dampers installed in:
  - A 100mm-thick aerated concrete wall with mortar seal
  - A 200mm-thick aerated concrete wall with a bulk density of 450kg/m<sup>3</sup> and with mortar seal
  - A 110mm-thick reinforced concrete floor with mortar seal
  - Light partition made using 98/48 type F (EN520) gypsum plasterboard panels

No other classification is authorised.

E	I		t		ve	-	ho	-	i	↔	o	-	S
<b>E</b>	<b>I</b>		<b>90</b>		<b>ve</b>	-	<b>ho</b>	-	<b>i</b>	↔	<b>o</b>	-	<b>S</b>

- Fire dampers installed in:
  - A type F gypsum plasterboard partition, with a mortar sealing, with a negative pressure of - 300 Pa and horizontal axis

No other classification is authorised.

E	I		t		ve	-	ho	-	i	↔	o	-	S
<b>E</b>	<b>I</b>		<b>90</b>		<b>ve</b>	-		-	<b>i</b>	↔	<b>o</b>	-	<b>S</b>

- Fire dampers installed in:
  - A 100mm-thick aerated concrete wall with plaster seal
  - A 150mm-thick reinforced concrete floor with plaster seal
  - A 150mm-thick aerated concrete floor with plaster seal

No other classification is authorised.

E	I		t		ve	-	ho	-	i	↔	o	-	S
<b>E</b>	<b>I</b>		<b>120</b>		<b>ve</b>	-	<b>ho</b>	-	<b>i</b>	↔	<b>o</b>	-	<b>S</b>

- Offset fire dampers using a sheet metal duct protected by stone wool:

**The maximum approved operating vacuum pressure in this case is -300Pa.**

Where the seal is made using:

- 60mm-thick PROMASTOP CB panels
- Or
- 2 x 50 mm-thick PROMASTOP CB, Promastop CB-CC 50 or HILTI-CFS-CT\_B\_1s panels

+ with IFW installation kit

E	I	-	t		ve	ho	i	<->	o	S
<b>E</b>	<b>I</b>		<b>60</b>		<b>ve</b>		<b>i</b>	<->	<b>o</b>	<b>S</b>

Where the seal is made using PROMASTOP CB, Promastop CB-CC 80 or 80mm-thick HILTI-CFS-CT\_B\_1s panels or 2 x PROMASTOP CB or Promastop CB-CC 50 or 100mm-thick HILTI-CFS-CT\_B\_1s panels + with IFW installation kit

E	I	-	t		ve	ho	i	<->	o	S
<b>E</b>	<b>I</b>		<b>90</b>		<b>ve</b>		<b>i</b>	<->	<b>o</b>	<b>S</b>

- Offset fire dampers using a sheet metal duct protected by GEOFLAM F 45, GEOFLAM F LIGHT 35 plates:

**The maximum approved operating vacuum pressure in this case is -500Pa.**

E	I	-	t		ve	ho	i	<->	o	S
<b>E</b>	<b>I</b>		<b>120</b>		<b>ve</b>		<b>i</b>	<->	<b>o</b>	<b>S</b>

- Offset fire dampers using a duct made with GEOFLAM F 45, GEOFLAM F LIGHT 35 plates:

The maximum approved operating vacuum pressure in this case is -500Pa.

E	I	-	t		ve	ho	i	<->	o	S
E	I		120		ve		i	<->	o	S

The above performances of the elements are valid for heating as described in section 5.1.1 of the European standard EN 1363-1.

## 9. FIELD OF APPLICATION OF THE RESULTS

### 9.1. GENERAL

The requirements related to the field of application of all the fire dampers tested in accordance with EN 1366-2 apply, as well as the following items.

### 9.2. DIMENSIONS OF THE FIRE DAMPER

In accordance with section 13.1 of the standard EN 1366-2, the classifications indicated in section 8.2 of this classification report are valid for all fire dampers of the same type (including all the side reports), provided the maximum flow cross-section dimensions do not exceed 800 x 600mm and that the minimum flow cross-section dimensions are not less than 200 x 100mm.

### 9.3. FIRE DAMPERS INSTALLED WITHIN STRUCTURAL OPENING

A test result obtained for a fire damper installed within a structural opening is only applicable to fire dampers of the same type installed in the same orientation and position in relation to the supporting construction as that tested.

### 9.4. FIRE DAMPERS REMOTE FROM A WALL OR FLOOR

A test result obtained for a fire damper remote from a wall or floor is applicable to fire dampers of the same type installed with the same ductwork details as tested:

- Mounted remote from a wall and attached to a length of a horizontal fire resisting ductwork when tested remote from a wall.
- Mounted remote from a floor and attached to a length of vertical fire resisting ductwork on the side above the floor when tested above the floor.
- Mounted remote from a floor and attached to a length of vertical fire resisting ductwork on the side below the floor when tested below the floor.
- Mounted up to the same distance that was tested from the wall/floor and up to the same width and height of duct tested.

A test result obtained with the duct passing through a standard supporting construction is applicable to a supporting construction with a fire resistance equal to or greater than that of the standard supporting construction used for the test (thicker, denser, more layers of board, as appropriate).

Test results obtained with duct passing through flexible vertical supporting constructions may be applied to rigid supporting constructions of a thickness equal to or greater than that of the element used in the tests, provided that the classified fire resistance of the rigid supporting construction is greater than or equal to the one used for the test.

### 9.5. FIRE FROM ABOVE

Fire dampers tested horizontally in floors with fire from below are acceptable in installations where fire might come from above.

### 9.6. SEPARATION BETWEEN FIRE DAMPERS AND BETWEEN FIRE DAMPERS AND CONSTRUCTION ELEMENTS

In accordance with section 13.5 of the standard EN 1366-2, the fire classifications indicated in section 8.2 of this classification report apply, in practice, with a minimum spacing:

- a) of 50mm between fire dampers installed in separate ducts;
- b) of 50mm between the fire damper and a construction element (wall);
- c) of 25mm between the fire damper and a construction element (floor).

### 9.7. SUPPORTING CONSTRUCTIONS

A test obtained for a fire damper mounted in or on the face of a standard supporting construction is applicable to a supporting construction of the same type with a fire resistance equal to or greater than that of the standard supporting construction used in the test (thicker, denser, more layers of boards, as appropriate).

The test result can also apply to cellular or hollow masonry blocks or slabs that have a fire resistance time equal or greater than the fire resistance required for the fire damper installation.

Test results obtained with dampers installed in flexible vertical supporting constructions may be applied to rigid supporting constructions of a thickness equal to or greater than that of the element used in the tests, provided that the classified fire resistance of the rigid supporting construction is greater than or equal to the one used for the test. The sealants used shall be the same as those tested. Any fasteners used shall be fire rated to suit the supporting construction that is used.

Test results obtained with dampers installed in insulated flexible vertical supporting constructions may be applied to applications where the same flexible vertical supporting construction is uninsulated - aperture framing shall be used using the same materials as used in the test partition construction, using the same number of boards as was tested.

Test results obtained with dampers installed in flexible vertical supporting constructions made with steel studs are not applicable to flexible vertical supporting constructions made using timber studs.

Test results obtained with dampers installed in aerated concrete are applicable to rigid constructions made from hollow blocks, provided that the holes are filled/closed before the addition of the final penetration seal.

If a specific supporting construction different from those described in standard EN 1366-2 – paragraph 7.2 is selected, the test results obtained are applicable only to that specific wall, partition or floor having a thickness and/or density equal or greater than that tested.



### 9.8. BLADE PIVOT AXIS

Tests with the actuator mounted at the bottom of the fire damper for a test with the blades with a vertical pivot axis shall allow the damper to be installed with the actuator at the top of the unit.

Maizières-lès-Metz, 23 August 2021

X   
Charlotte SCHNELLER

---

Project Leader  
Signé par : Charlotte SCHNELLER

X   
Romain STOUVENOT

---

Supervisor  
Signé par : Romain STOUVENOT

## APPENDIX

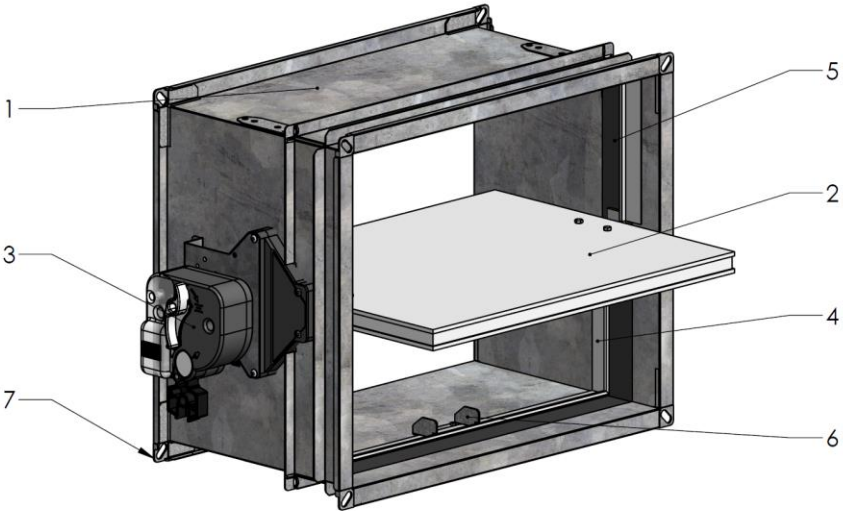
	<p>Reference - Subject - Date  <b>CULT_Commercial_08_08_14</b></p>	<p>Plate  A 2/2</p>				
<div style="text-align: center;">  </div> <p>1. Refractory casing made of galvanised steel  2. Damper blade  3. Operating mechanism with transmission  4. Cold sealing  5. Intumescent strip  6. Positioning plate  7. Connection frame PG20  8. Product identification</p>						
<b>PRODUCT RANGE</b>						
	<table border="1" style="width: 100%; border-collapse: collapse;"> <tr> <td style="width: 50%; text-align: center;">Minimum dimensions</td> <td style="width: 50%; text-align: center;">Maximum dimensions</td> </tr> <tr> <td style="text-align: center;">200x100(*)</td> <td style="text-align: center;">800x600(*)</td> </tr> </table>		Minimum dimensions	Maximum dimensions	200x100(*)	800x600(*)
Minimum dimensions	Maximum dimensions					
200x100(*)	800x600(*)					
WxH(mm)						
W= Width H= Height						
<p>* W/H per step of 50mm, intermediate dimensions available at an additional cost</p>						
<p>Plan Title:</p>						

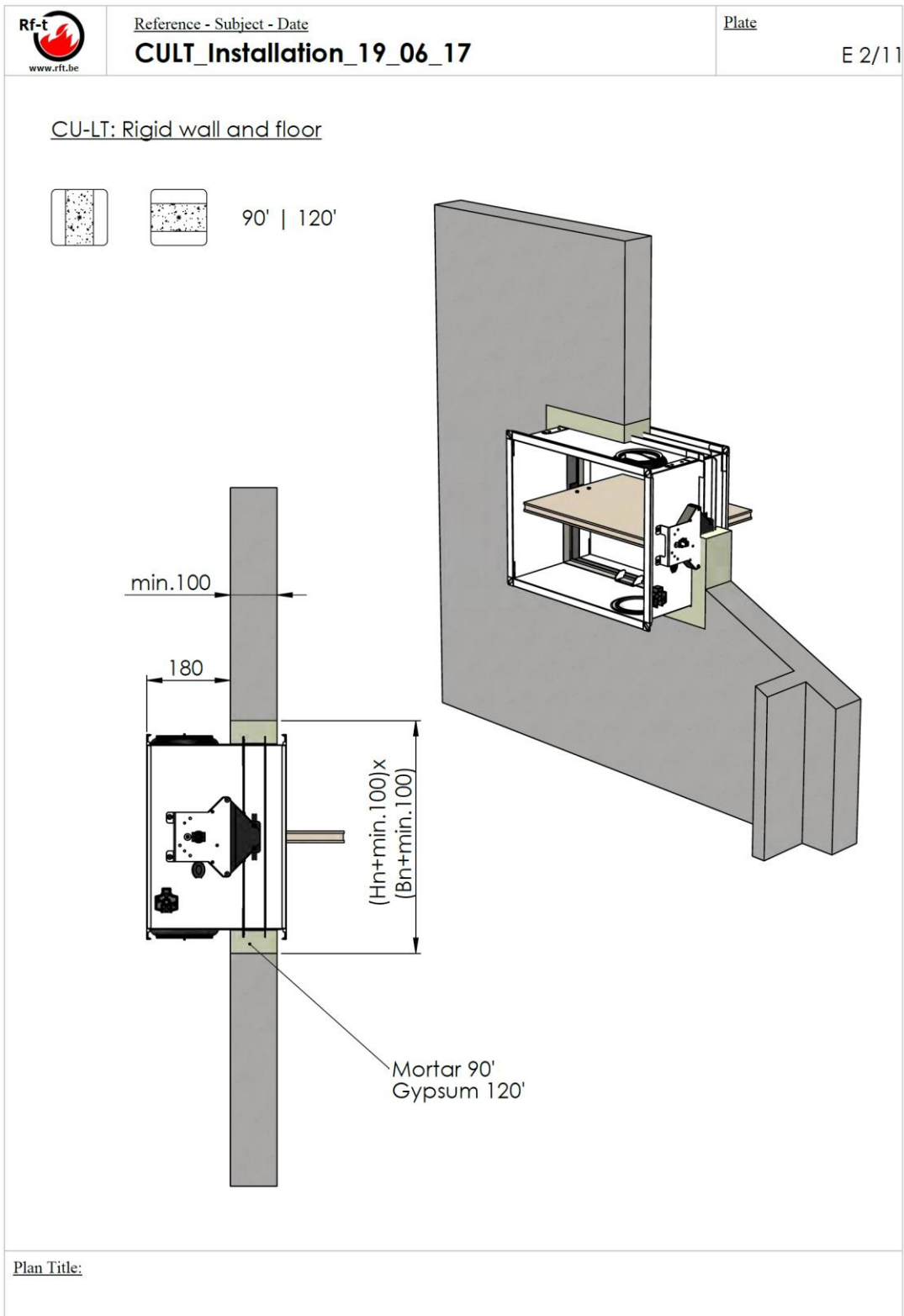

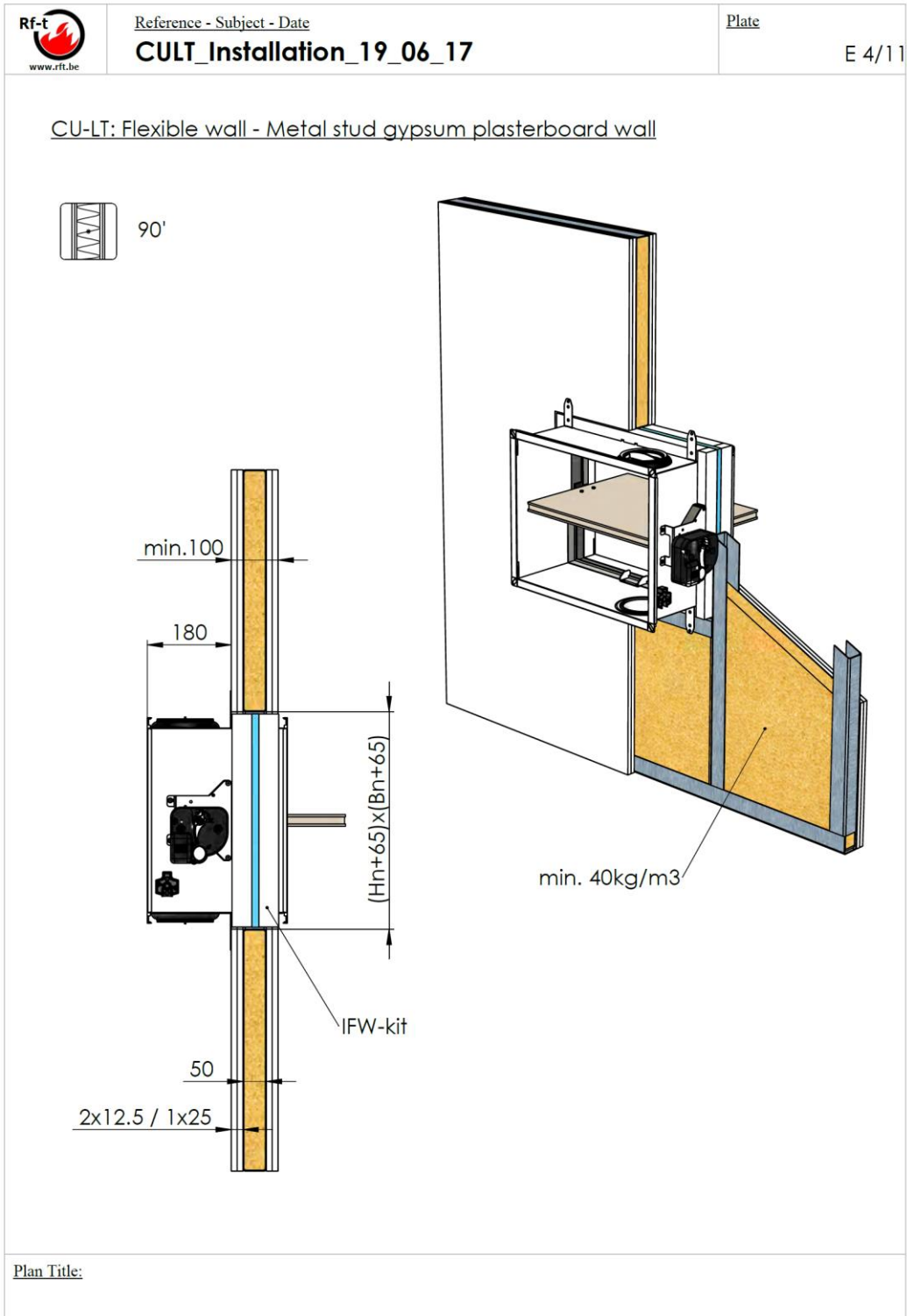

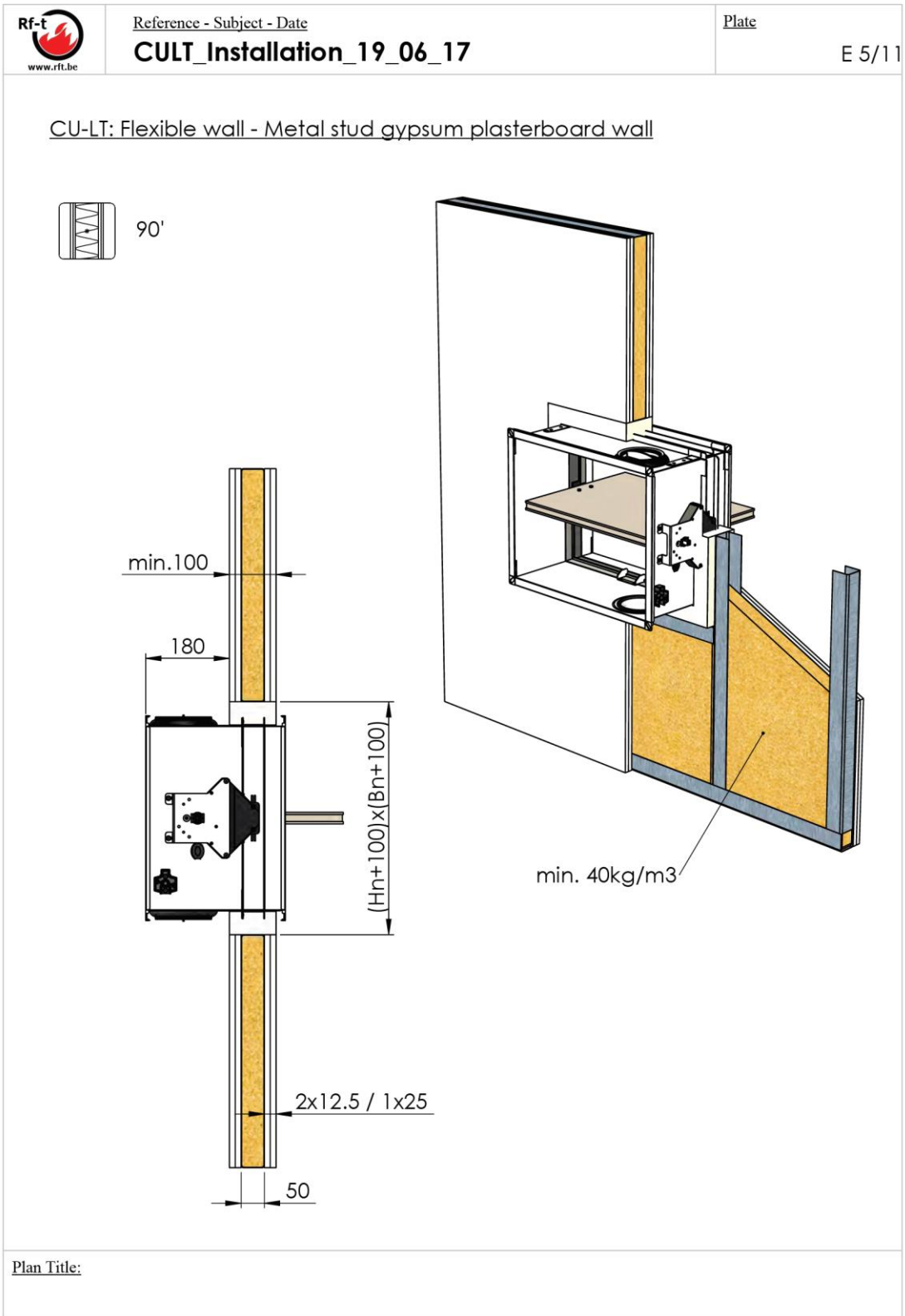

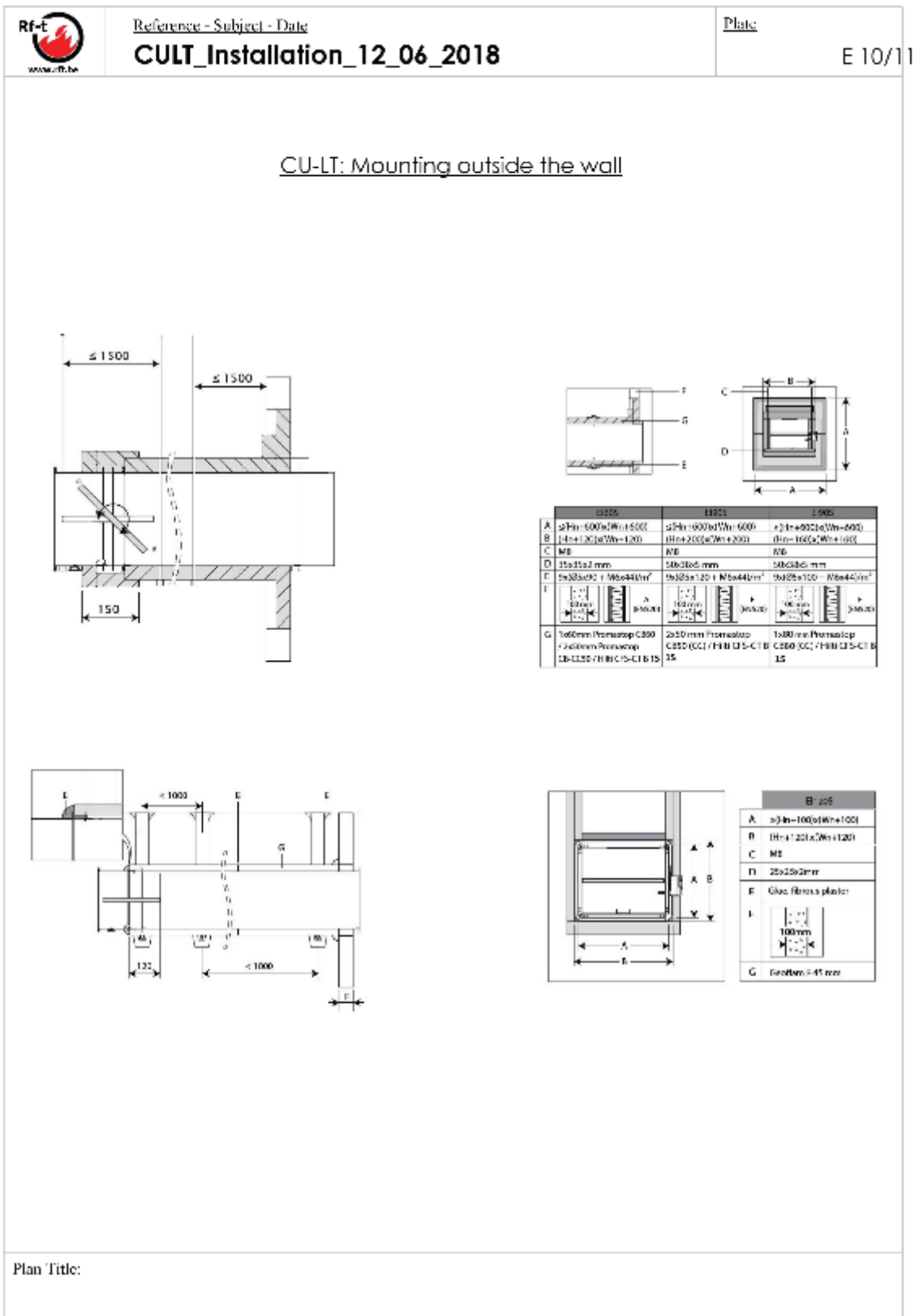

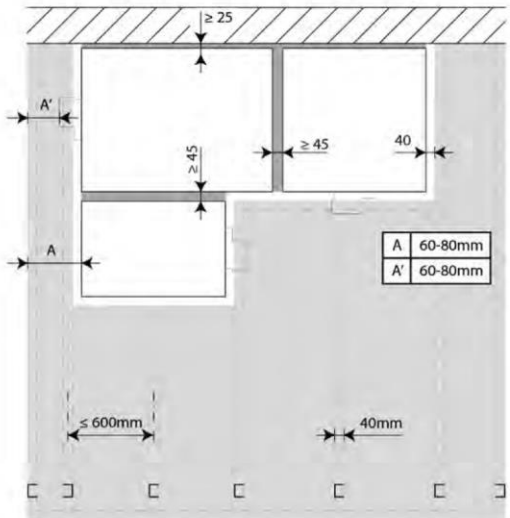
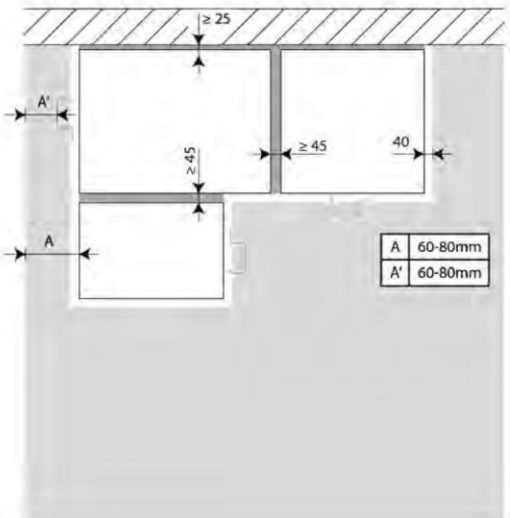
 <p>www.rf-t.be</p>	<p>Reference - Subject - Date  <b>CULT_Installation_19_06_17</b></p>	<p>Plate  E 11/11</p>
<p style="text-align: center;"><u>CU-LT: Mounting flexible wall at 0 distance</u></p>  <p style="text-align: center;"><u>CU-LT: Mounting rigid wall at 0 distance</u></p> 		
<p><u>Plan Title:</u></p>		